

SUBSURFACE OR UNDERGROUND DRIP IRRIGATION SYSTEM				
AREA	SF	ACRES	GAL/DAY	
UG#1	PROPOSED	325,185.38	7.47	149,304.58
UG#2	FUTURE	229,909.25	5.28	105,559.80
UG#3	FUTURE	228,445.83	5.24	104,887.89
UG#4	FUTURE	64,193.74	1.47	29,473.71
UG#5	FUTURE	98,122.65	2.25	45,051.72
TOTAL		945,856.85	21.71	434,277.71

SURFACE OR OVERLAND DRIP IRRIGATION SYSTEM				
AREA	SF	ACRES	GAL/DAY	
OL#1	PROPOSED	387,306.48	8.89	222,283.33
OL#2	FUTURE	41,445.57	0.95	23,786.48
OL#3	FUTURE	44,921.59	1.03	25,781.45
OL#4	FUTURE	106,961.52	2.46	61,387.47
OL#5	FUTURE	43,331.39	0.99	24,868.80
OL#6	FUTURE	71,152.30	1.63	40,835.80
OL#7	FUTURE	74,588.47	1.71	42,807.89
OL#8	FUTURE	30,316.71	0.70	17,399.40
OL#9	FUTURE	20,478.88	0.47	11,753.26
OL#10	FUTURE	60,441.51	1.39	34,688.65
OL#11	FUTURE	272,045.07	6.25	156,132.39
TOTAL	TOTAL	1,152,989.49	26.47	661,724.91

BOYER AVENUE (A.K.A. EIGHTH STREET)

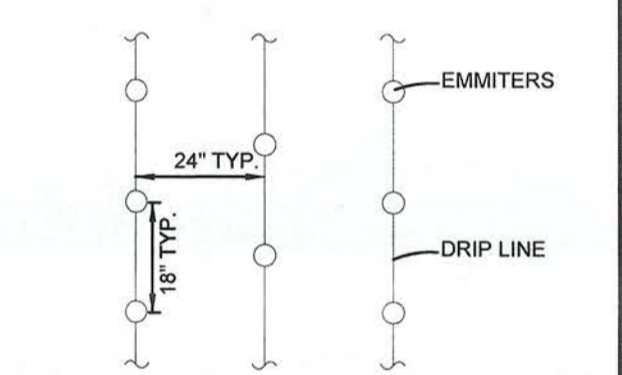
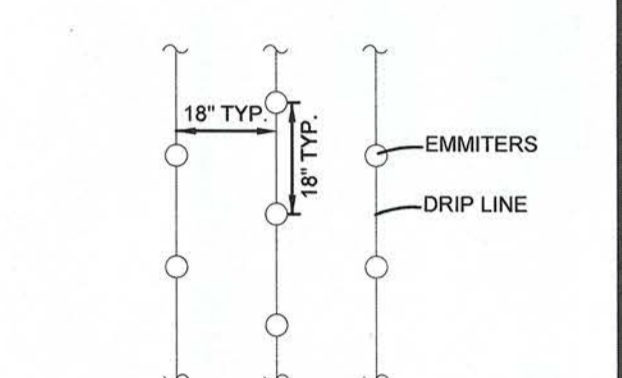
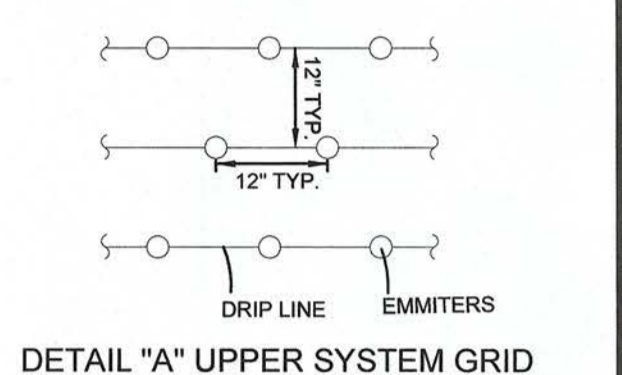
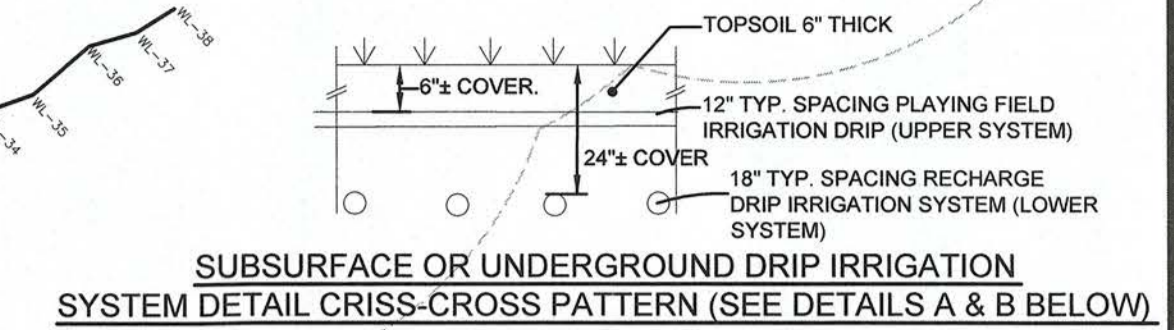
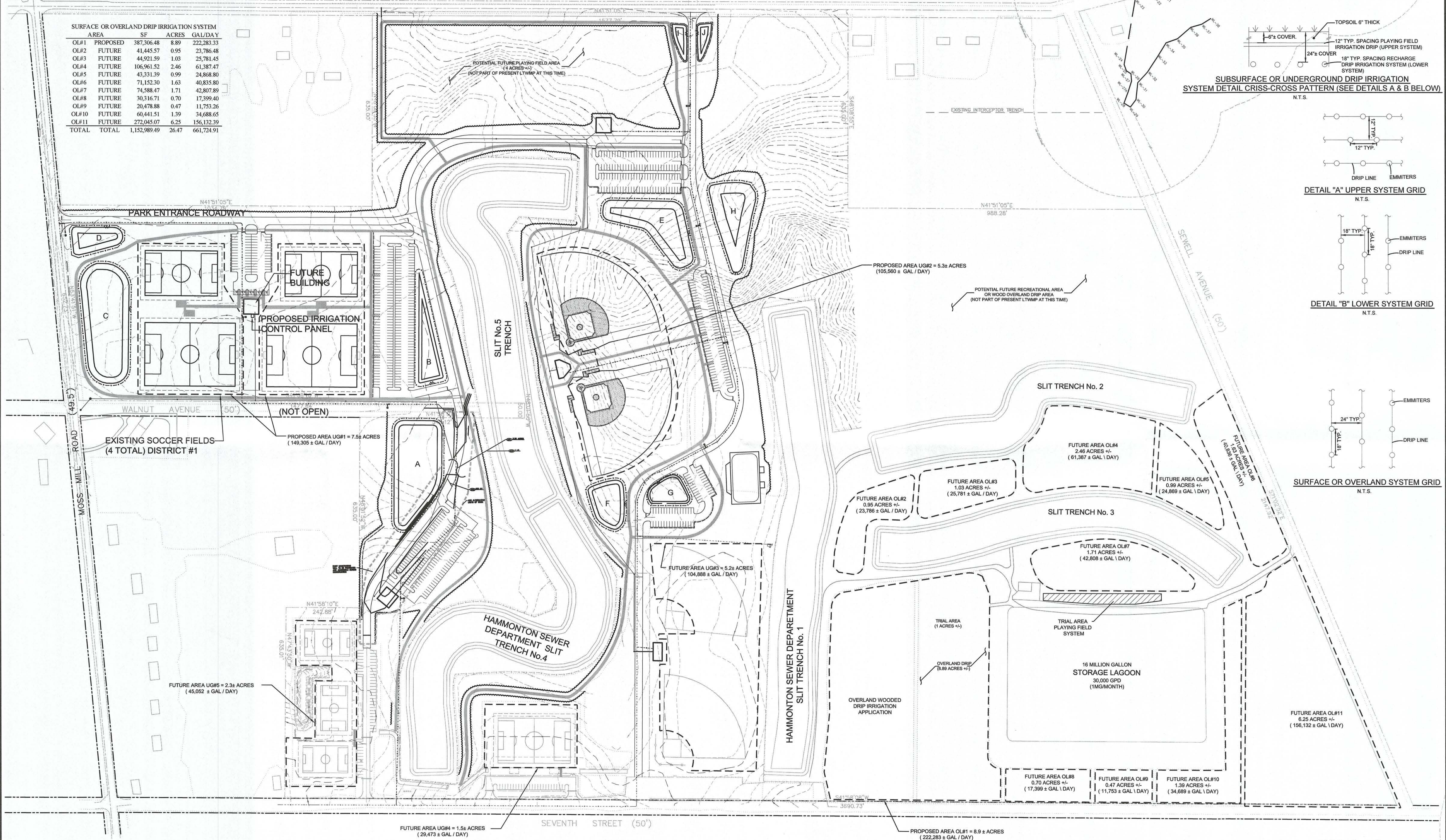

NOTE: WOODS LINE INSIDE FENCE OBTAINED FROM 2007 NJ AERIAL No. F16D14

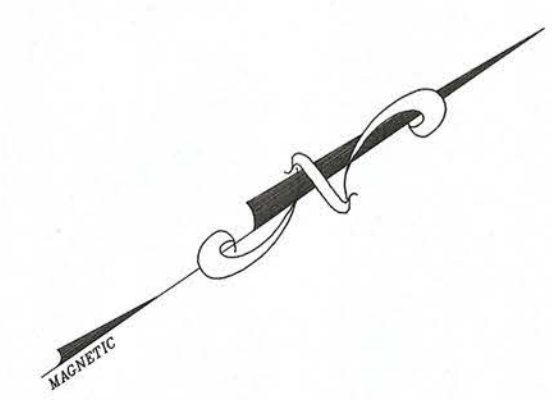
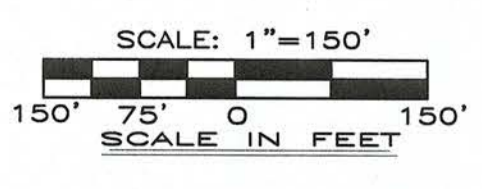

DRAWING LOCATION: W:\FILEROOM\CS1119008\ENGDWG\2014 IRRIGATION DESIGN.DWG
 LAST DATE SAVED: 4/16/2014
 LAST SAVE BY: DDEMP

W:\FILEROOM\CS11175003\ENGDWG\H01.E DESIGN.DWG 2/3/2011 9:17:23 AM EST

Robert A. Vetteuse
 PROFESSIONAL ENGINEER
 NEW JERSEY LICENSE NO. 23898

arh adams, rehmann & heggan
 ENGINEERS SURVEYORS PLANNERS
 associates, inc.
 850 south white horse pike
 hammonden, nj 08037-2019
 tel (609) 561-0482
 fax (609) 561-8909
 certificate of authorization no. 24GA27973300

NO.	DATE	DESCRIPTION	BY	APP'D
1	4/16/14	DRIP TUBING DETAIL	DDEMP	DDEMP
2	2/18/2014	LYTWP REPORT	DDEMP	DDEMP

CONCEPTUAL DESIGN APPROVAL PLAN FOR
 BOYER AVENUE SITE
**SURFACE AND SUBSURFACE
 DRIP IRRIGATION COMPONENTS**
 TOWN OF HAMMONTON ATLANTIC COUNTY NEW JERSEY

DATE:	MARCH 10, 2008
SCALE:	1"=150'
DRAWN BY:	MAK
CHECKED BY:	KEC
PROJ. NO.:	11-50058